

VIEW A-A  
(MOUNTING INTERFACE)

NOTE: 1  
DESIGN CODE:  
NS-EN 13445:2009 / ISO 13628-8

NOTE: 2  
TECHNICAL CLASSIFICATION:  
Article Type: 003-Valve Stabs  
Main Group: 3.07. Dual Bore-Valvestab  
Intermediate Group: 3.42.2. Receptacle  
Sub Group: 3.42.103.6. Hexa

NOTE: 3  
INTERFACE INFORMATION:  
Pressure Rating Bar: 690  
Material: Semi Permanent  
Weight: 22,1 kg  
Volume: 2,89 dm<sup>3</sup>  
Surface Area: 6227 cm<sup>2</sup>  
Hydraulic: 3/8" BSP  
Mechanical: 8xM10 (45x45x45)  
Electrical: N/A  
Com. & Protocol: N/A

NOTE: 4  
ADDITIONAL INFORMATION:  
Valve Stab Receptacle with 6 individual hydraulic lines for long term submersion, when connected to external CP system. Equipped with a key system to ensure only male stab with correct key (white colour) can be inserted (BA8369).  
A mechanical lever arm reduces stab mating force.  
When stab is inserted and valves opened (red position) a weak link system ensures that the stab can be pulled out in an emergency situation, emergency release force approx. 3kN.  
This receptacle is special configured with an open cartridge (no seals) in port no. 1 which enables fluid communication between receptacle port 1 and ambient seawater when receptacle is in Closed Position (green).  
For more information - request usermanual 600142-TD-0001.

NOTE: 5  
SPAREPARTS:  
<http://e-sea.bluelogic.no/main.aspx?page=article&artno=BB1053>

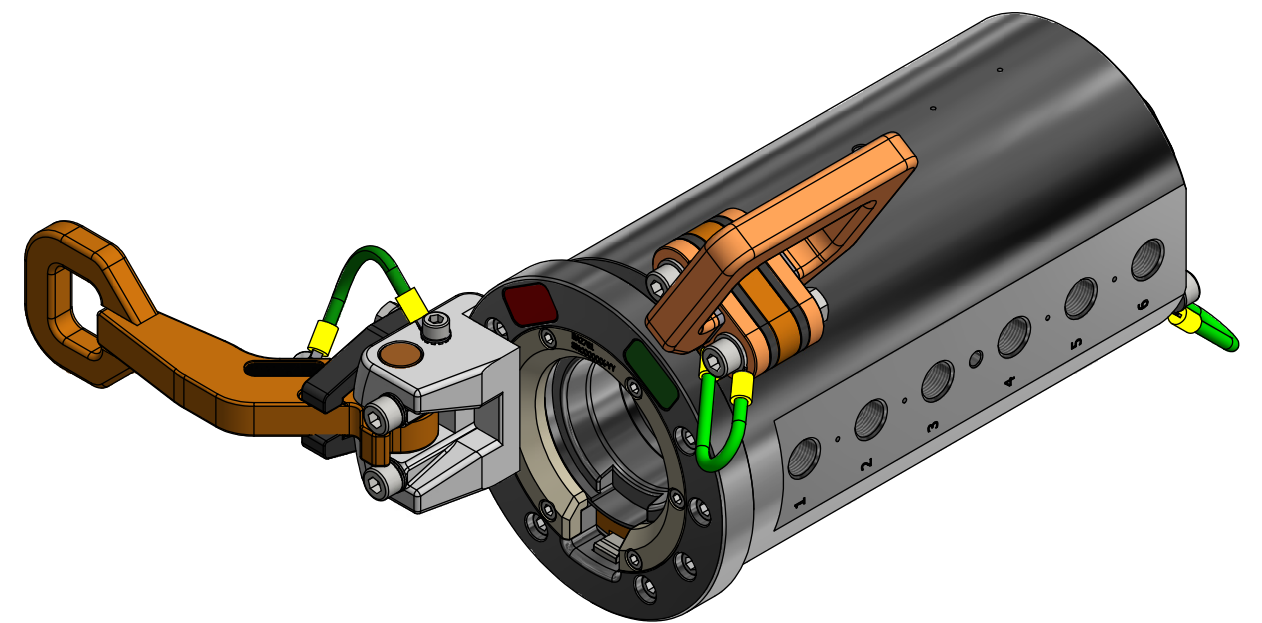

WEB REFERENCE LIST				
ITEM	QTY	PART No.	TITLE	WEBLINK
1	1	BA9089	Lock Mechanism Ø55/Ø57 HP VStab V2 White	<a href="http://e-sea.bluelogic.no/main.aspx?page=article&amp;artno=BA7466">http://e-sea.bluelogic.no/main.aspx?page=article&amp;artno=BA7466</a>
2	1	BA8495	Cartridge Special	
3	1	BA7466	Ø55/Ø57 HP VStab Rec 10k Semi Perm BSP 3/8" Double Seal	<a href="http://e-sea.bluelogic.no/main.aspx?page=article&amp;artno=BA7466">http://e-sea.bluelogic.no/main.aspx?page=article&amp;artno=BA7466</a>
03	1.11.2016	9-IFU	(Issued for Use)	WTJ LGH WTJ
02	5.7.2016	9-IFU	(Issued for Use)	WTJ LAE WTJ
01	31.3.2016	2-IFT	(Issued for Tender)	WTJ HSE WTJ
Rev.	Date	Reason for issue	Revision change	Made Chk'd Appr.

**BLUE LOGIC**

Dwg Scale:  
NTS  
Dwg Proj:  
Dwg Format:  
A3

Drawing title:  
Ø55/Ø57 HP VStab Rec wCartridge BA8495 Port 1 & White Key

Drawing number:  
BA8373

Rev:  
03